

Catalog #77-4001

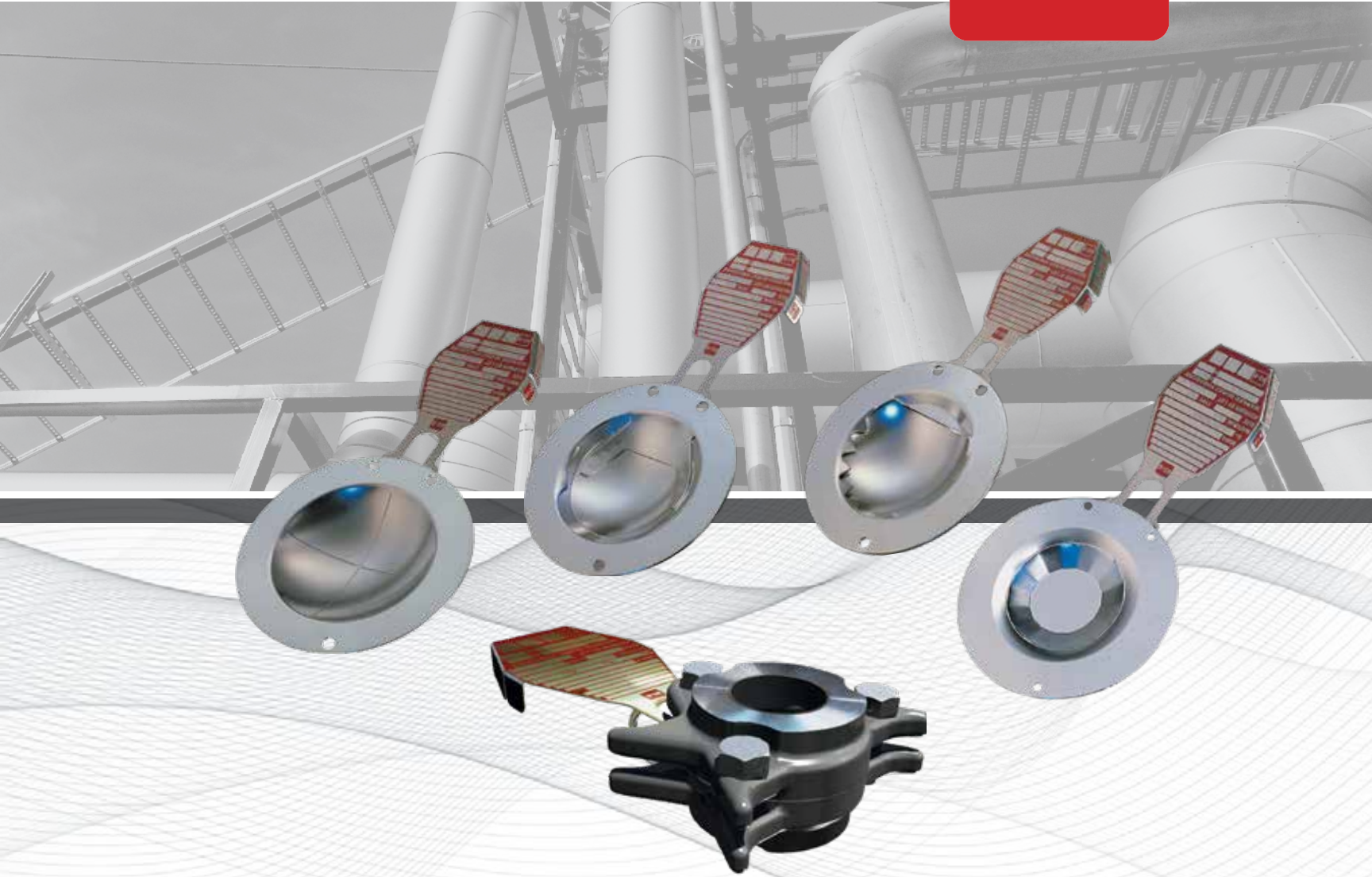

# The Sta-Saf<sup>®</sup> System

Reverse Buckling Technology





# Sta-Saf® System

The Sta-Saf® System includes 11 reverse buckling rupture disk models. These rupture disks offer the optimum performance attributes consisting of high operating margins, excellent resistance to cycling and pulsating service, and overall serviceability in demanding process environments.

The selection of the appropriate rupture disk from the Sta-Saf family is determined by specifications and requirements of the application. The contents of this catalog provides a simple path to determining the most appropriate disk service phase requirements.

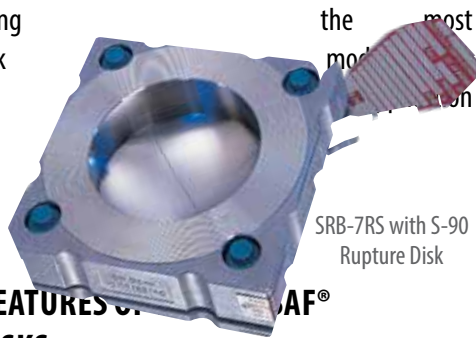

## STANDARD FEATURES OF STA-SAF® FAMILY OF DISKS

- High operating ratio up to 100% (CE) / 95% (ASME)
- Full vacuum resistance
- Solid metal construction enabling optimum leak tightness
- Designed for non-fragmentation
- Recommended for isolation of pressure relief valves
- Three-dimensional stainless steel tag with product identification and traceability data, as well as code symbol stamps as required

## OPERATING PRESSURE RATIO

Sta-Saf reverse buckling disks can be operated up to 95% of the marked burst pressure (or up to 100% of the minimum burst pressure) for burst pressures above 40 psig (2.76 barg). For burst pressures less than 40 psig, the maximum operating pressures may be lower (consult product specific information).

Rupture disks respond to differential pressure. Please take into account the service conditions at the inlet and outlet of a rupture disk when completing specifications.

## MAXIMUM RECOMMENDED TEMPERATURE

For each material the upper temperature unit has been determined from the recommendations of material manufacturers and end user experience. Rupture disk technology uses nickel and its alloys to provide the user with a range of corrosion resistance capabilities and thermal stability particularly in the case of alloy 600.

## Material Selection

BS&B manufactures rupture disk pressure relief devices on a wide range of materials in order to meet customer selection design and operational requirements. The user is advised to determine and select the appropriate material for the application conditions.

An incorrect material choice may result in performance issues including corrosion of disk material that may affect performance and leak tightness characteristics.

Material	Disk types	Maximum Recommended Temperature
Nickel (alloy 200)	S-90, RLS, JRS, FRS, FRL, SK <sub>R</sub> , Sigma, Sigma EXL, LPS, SRD, SRD-L	750°F (399°C)
Monel® (alloy 400)	S-90, RLS, JRS, FRS, FRL, SK <sub>R</sub> , Sigma, Sigma EXL, LPS, SRD, SRD-L	900°F (482°C)
Inconel® (alloy 600)	S-90, RLS, JRS, FRS, FRL, SK <sub>R</sub> , Sigma, Sigma EXL, LPS, SRD, SRD-L	1100°F (593°C)
316 stainless steel	S-90, RLS, JRS, FRS, FRL, SK <sub>R</sub> , Sigma, Sigma EXL, LPS, SRD, SRD-L	900°F (482°C)
Hastelloy® C-276 (alloy C-276)	S-90, RLS, JRS, FRL, SK <sub>R</sub> , Sigma, Sigma EXL, LPS, SRD, SRD-L	900°F (482°C)
Titanium	SK <sub>R</sub> , SRD, SRD-L	572°F (300°C)
Tantalum	RLS, FRL, SK <sub>R</sub> , LPS, SRD, SRD-L	500°F (260°C)
Aluminum	S-90	250°F (120°C)
Fluoropolymer liner (PTFE, PFA)	S-90, RLS, JRS, FRS, FRL, SK <sub>R</sub> , Sigma, Sigma EXL, LPS, SRD, SRD-L	500°F (260°C)
Fluoropolymer liner (FEP)	S-90, RLS, JRS, FRS, FRL, SK <sub>R</sub> , Sigma, Sigma EXL, LPS, SRD, SRD-L	400°F (204°C)

Fluoropolymer film liners are available as an additional corrosion barrier with most BS&B rupture disks. Order as "fluoropolymer liner" when required. Liners are typically applied to the inlet (process) side of the rupture disk; however, some disk types allow for liners to be applied to both the inlet and outlet side of the rupture disk. When a specific liner material is required (FEP, PFA, PTFE), the customer shall specify.

*Note: Hastelloy® is a registered trademark of Haynes International Inc. Monel® and Inconel® are registered trademarks of Special Metals Corporation and its subsidiaries.*



## MANUFACTURING DESIGN RANGE (MDR)

MDR is a range of pressure, always applied to the minus side of the user requested burst pressure for Sta-Saf rupture disks, which simplifies disk fabrication testing and provides economic benefit to the user where such an added MDR can be accommodated by the application. MDR choices are provided for all Sta-Saf rupture disks.

**MDR= 0%:** where the user requires the tightest margin between normal service pressure and burst pressure, a zero range disk should be used.

**MDR= -5%:** applied to the requested burst pressure, a -5% range allows an additional 5% MDR applied on the minus side of the user requested burst pressure.

**MDR= -10%:** applied to the requested burst pressure, a -10% range allows an additional 10% MDR applied on the minus side of the user requested burst pressure.

**Example:** Requested burst pressure 100 psig (6.89 barg). Agreed MDR - 10%. Therefore the marked burst pressure will be between 90 psig (6.20 barg) and 100 psig (6.89 barg) for all disks of the delivered lot.

\*The ASME code defines the MDR as a range of pressures within which the marked burst pressure must fall to be acceptable for a particular requirement as agreed upon between the rupture disk manufacturer and the user or his agent.

Note: MDR and burst tolerance are additive. In the European / ISO case, the burst tolerance and MDR are simply combined. In the ASME case, the 'marked burst pressure' for a lot of rupture disks must be a value within the agreed MDR and then the burst tolerance is applied.

### The two-step approach to set pressure specification:

- Decide between ASME / North American (with or without 'UD' stamp) and European (with or without 'CE' mark) / ISO standards
- Select the Manufacturing Design Range appropriate to the application and check that it is available for the disk type selected. (0, -5 or - 10%)

(Consult BS&B or your BS&B sales representative for assistance)

## PRESSURE/TEMPERATURE RELATIONSHIP

The burst pressure of all rupture disks is partially determined by the physical properties of the material employed. Tensile strength varies with temperature, which leads to variation in burst pressure. Reverse buckling technology is the least sensitive to temperature variations and is used by all Sta-Saf rupture disks. However, for the highest accuracy and reliability of performance, BS&B certifies each lot (batch) of Sta-Saf rupture disks by testing at the users' specified temperature (burst temperature).

Where operating pressure and temperature may rise rapidly, the user should, as accurately as possible, specify the expected coincident temperature located at the disk during the moment of the expected rupture. BS&B can provide advice for such applications. Inconel (alloy 600) provides excellent thermal stability for applications that experience a wide range of service temperatures at which overpressure might occur.

Whether specified temperature of a rupture disk is outside ambient temperature of 72°F (22°C), the disk is tested at the temperature to ensure accuracy of performance. For applications which have operating temperatures that may exceed the specified burst temperature, please consult the local BS&B sales office for technical guidance regarding the proper rupture disk specification.

## STA-SAF BURST PRESSURE TOLERANCES

All of the Sta-Saf rupture disks offer the same burst tolerance considerations when completing a specification. Whether the ASME/North American or Pressure Equipment Directive (PED)/ European approach to burst pressure and tolerance is used, both the burst tolerance and an optional manufacturing design range should be considered.

Burst tolerance is the range of pressure(+/-), relative to the marked burst pressure, over which a rupture disk can be expected to burst. Burst tolerance is +/-5% for marked burst pressures of 40psig or greater and +/-2psig for marked burst pressures rated from 15-40psig. **For the LPS rupture disks, consult the chart on page 8 for special tolerances.**

### BURST TOLERANCE

Marked Burst Pressure	Burst Tolerance
≤ 40 psig (2.76barg)	± 2 psig (0.138barg)
> 40 psig (2.76 barg)	± 5%



# Sigma EXL™ and Sigma™ Rupture Disks for the Highest Operating Pressure in Gas or Liquid Service

## INTRODUCTION

The Sigma EXL reverse buckling rupture disk has been developed to provide the highest operating pressure capability available from a rupture disk pressure relief device. Sigma EXL technology and its safety head combine the accuracy and reliability of reverse buckling disk technology with unique disk and safety head design features that enable the Sigma EXL disk to operate to 95% of the marked burst pressure (100% of minimum burst pressure according to CEN ISO 4126-2 standards). The Sigma EXL rupture disk embraces SAF™ technology (structural apex forming), the central feature on the disk dome enhancing burst pressure



accuracy and service durability.

At its burst pressure, the Sigma EXL rupture disk dome reverses and opens by shearing around a circular score line located near the perimeter of the dome. The score line engages with one or more points on the integral hinge down stream of the disk. The disk opens with the central petal supported by the hinge, avoiding fragmentation. The Sigma EXL is offered with a simple burst pressure tolerance.

No MDR needs to be considered for this high operating ratio disk (effectively a 'zero' range disk). Prior to delivery, the performance of every Sigma EXL disk is assured by proof pressure testing each disk to its maximum recommended operating pressure. The Sigma EXL provides the user with the highest operating ratio of any rupture disk pressure relief device.

## FEATURES

- Sizes 1-12 inches (25-300 mm)
- High operating ratio: 95% of marked burst pressure
- High operating ratio: 100% of minimum burst pressure (CEN ISO4126-2)
- Standard 0% MDR, optional -5%. (Sigma EXL standard is 0% MDR. For Sigma, 5% is standard)
- Designed for non-fragmentation
- Designed for gas, liquid and multi-phase flow conditions
- Fail safe: damage safety ratio <1
- SAF™ technology
- Vacuum resistant
- Smooth process side of disk resists product accumulation
- Long service life in pressure cycling or pulsating conditions
- For installation in Types SRI-7RS, SRB-7RS, S90-7R, SRB-7FS and TR-Series pretorqued safety heads
- US patents 6178983, 6321582, 6446653, 6494074 and international patents apply
- AQA Quality Assurance

Marked Burst Pressure	Burst Tolerance
≤ 40 psig (2.76 barg)	± 2 psig (0.138 barg)
> 40 psig (2.76 barg)	± 5%

## BURST TOLERANCE

### MANUFACTURING DESIGN RANGE (MDR)

The Sigma EXL rupture disk has a standard "0%" MDR, and the Sigma rupture disk less a "-5%" range.

### OPERATING RATIO

Sigma EXL reverse buckling disks can sustain operating pressures to 95% of their marked burst pressure, or to 100% of their minimum burst pressure. (For disks certified under CEN ISO4126-2 'performance tolerance', the Sigma EXL disk can sustain operating pressures to 100% of the burst pressure less the negative performance tolerance.)

Sigma reverse buckling disks having a -5% MDR may also sustain operating pressures to 95% of their marked burst pressure, or to 100% of their minimum burst pressure. However, this operating pressure may be lower than for a Sigma EXL disk by as much as the -5% MDR.



## CERTIFICATION

The certification procedure for Sigma EXL™ and Sigma™ rupture disks exceeds those required by standard industry codes and standards that require limited destructive testing to validate burst pressure and permit acceptance of the lot with any burst test distribution and uncentered test data. The Sigma EXL and Sigma disks' test data is graphically presented on their burst test certificate (see example). The curve includes 'in process' and final certification burst test data to build a clear picture of the burst pressure distribution. Only when the data is appropriately centered and distributed is the lot accepted for shipment. The certificate indicates also the burst test results of rupture disks tested from the 'lot' for the Quality Department final acceptance - the quantity of test results is determined by the certification code or standard chosen by the user.

Sigma EXL and Sigma rupture disks are also validated for liquid service for each lot using a fully hydraulic burst test system and the burst test certificate endorsed accordingly.

The combination of statistical control techniques for burst pressure, and proof pressure testing of Sigma EXL and Sigma rupture disks enables their application to the highest operating pressures available from the rupture disk industry.

### BURST TEST CERTIFICATE

SUPPLIED TO:		DATE: 08-Dec-17	PO No: 17102215
BS&B LOT No: 17096050-1			
SIZE: 3" DN 80			
TYPE: SIGMA-EXL			
MATERIAL: 316, TI	HEAT No: N-22352		
QUANTITY SUPPLIED: 3	TAG No(s): 607-456-1237		

We certify that the Rupture Disks covered by this data have been manufactured, inspected and tested in accordance with the parameters below.

BURST PRESSURE			
MARKED	UNITS	TOLERANCE	TEMP
375	psi(G)	+/- 5%	400 Deg F

BURST TEST RESULTS			
MARKED	UNITS	TOLERANCE	TEMP
1	490.00	psi(G)	72 Deg F
2	490.00	psi(G)	72 Deg F
3	377.00	psi(G)	400 Deg F
4	377.00	psi(G)	400 Deg F

PERFORMANCE TESTING		RESULTS
Burst Pressure Tests		PASS
Proof Pressure Test	100% MIN	PASS
Liquid Opening Test		PASS

Note: Burst test distribution curve generated using test data normalised to rated burst temperature.

BS&B SAFETY SYSTEMS LTD.  
Barnes Business Park,  
Limerick, Ireland  
Telephone: +353 61 227022  
Facsimile: +353 61 227087  
E-mail: sales@bs&b.ie  
www.bs&b.ie

BS&B SAFETY SYSTEMS, LLC  
7455 East 40th Street,  
Tulsa, OK 74145, USA  
Telephone: +1 918 462-2500  
Facsimile: +1 918 462-2604  
Toll Free: +1 888-212-7755  
E-mail: sales@us.bs&b-systems.com  
www.bs&b-systems.com

Manufactured & tested according to:  
**EN ISO 4126-2**

MARKED ASME Section XIII UD (stamp).

Quality Assurance

## DAMAGE SAFETY RATIO < 1

If a Sigma EXL series rupture disk is accidentally damaged, it will relieve pressure by bursting at or below its marked burst pressure. This fail safe design feature is called the damage safety ratio, and

with a value of 1 or less, will ensure that a damaged Sigma EXL or Sigma disk will not exceed the marked burst pressure, typically reversing and opening at a reduced pressure.

## SIGMA™ and Sigma EXL™ Disk Specifications Minimum / Maximum Pressure Rating at 72°F (22°C) PSIG (Barg)

Disk Size		Nickel Alloy 200				Monel® Alloy 400				Inconel® Alloy 600				Hastelloy® Alloy C-276				316ss			
		psig		barg		psig		barg		psig		barg		psig		barg		psig		barg	
in	mm	Min	Max	Min	Max	Min	Max	Min	Max	Min	Max	Min	Max	Min	Max	Min	Max	Min	Max	Min	Max
1	25	35	500	2.41	34.47	58	500	4.00	34.47	50	500	3.45	34.47	55	500	3.79	34.47	35	500	2.41	34.47
1.5	40	30	400	2.06	27.58	45	400	3.10	27.58	45	400	3.10	27.58	45	400	3.10	27.58	30	400	2.07	27.58
2	50	25	400	1.72	27.58	30	400	2.07	27.58	30	400	2.07	27.58	30	400	2.07	27.58	25	400	1.72	27.58
3	80	20	400	1.38	27.58	22	400	1.52	27.58	22	400	1.52	27.58	25	400	1.72	27.58	20	400	1.38	27.58
4	100	16	400	1.10	27.58	18	400	1.24	27.58	18	400	1.24	27.58	20	400	1.38	27.58	16	400	1.10	27.58
6	150	15	225	1.03	15.51	15	225	1.03	15.51	15	225	1.03	15.51	20	225	1.38	15.51	15	225	1.03	15.51
8	200	15	125	1.03	8.62	15	125	1.03	8.62	15	125	1.03	8.62	20	125	1.38	8.62	15	125	1.03	8.62
10	250	15	100	1.03	6.89	15	100	1.03	6.89	15	100	1.03	6.89	20	100	1.38	6.89	10	100	0.69	6.89
12	300	15	75	1.03	5.17	15	75	1.03	5.17	15	75	1.03	5.17	20	75	1.38	5.17	10	75	0.69	5.17

**Note:** Hastelloy® is a trademark of Haynes International Inc. Monel® and Inconel® are registered trademarks of Special Metals Corporation and its subsidiaries.



## AQA™ Advance Quality Assurance Reliability - Traceability - Accuracy for Sigma™ and Sigma EXL™ Rupture Disks

International Codes & Standards provide rules for quality testing of rupture disk devices (bursting disc devices) based upon destructive testing of examples of the product and the assumption that the remainder of the lot shares the same performance characteristics. This established focus on destructive testing is at the heart of the American ASME Code (Section XIII Division 1) and both the European and International Standards 4126 part 2. BS&B's AQA program elevates the rupture disk device quality process to establishing, recording and capturing critical characteristics of each disk in a lot to know that the anticipated consistency applies. When AQA is applied, facts regarding the delivered product are compared to the tested product ensuring reliability and accuracy of supply.

*US patent 9,168,619 applies; International patents pending.*

### WHAT IS AQA?

AQA begins with material preparation for rupture disk manufacture. Each coupon of material that might become a rupture disk is permanently marked with a serialized lot number. Established Codes & Standards have long required a lot number be applied to finished goods for traceability reasons. BS&B AQA implements individual traceability at the raw material stage. The thickness of each rupture disk coupon is verified for consistency and its data captured. Only coupons meeting BS&B's engineering standards proceed to the manufacturing process. All destructive burst tests are captured and logged to the individual material coupon combined lot number and serial number.

Completed rupture disks are photographed against a scaled background and the finished product image captured against the lot order file. At this point both physical inspection of the finished



*AQA 2D bar code applied to rupture disk flange*

goods & visual or software review of the captured images can be conducted. Image review minimizes product handling and offers a level of enhanced accuracy in verifying consistency of product characteristics between destructively tested and finished goods.

### HOW IS AQA TRACEABILITY ACHIEVED?

Traceability of BS&B rupture disks benefiting from AQA is achieved through the use of 2D bar codes applied to the rupture disk flange / rim area, any secondary component such as a downstream hinge, and the customary identification tag.

### AQA AVAILABILITY

AQA is available for type Sigma and Sigma EXL rupture disks. AQA is available with other rupture disk models upon request.



# SK<sub>R</sub><sup>TM</sup> the All Purpose Rupture Disk for Controlled Pressure Relief



The SK<sub>R</sub><sup>TM</sup> reverse buckling disk is designed with a circular score line located at the edge of the domed area on the downstream side of the disk. At the marked burst pressure, the disk's dome reverses and opens by shearing around the circular score. The SK<sub>R</sub> uses SAF<sup>TM</sup> technology (structural apex forming) enabling very low burst pressures to be achieved with excellent opening characteristics. An integral energy-absorbing hinge located on the downstream side of the disk enables the SK<sub>R</sub> to perform in gas or liquid service with superior flow performance. The hinge design interacts with the safety head bore to retain the SKR disk petal on opening, avoiding fragmentation.

## LINERS

Fluoropolymer liners are available in all sizes as optional on the process side of the disk.

### Temperature Range

FEP -40°F to 400°F (-40°C to 205°C)

PTFE -40°F to 500°F (-40°C to 260°C)

## TYPE SK<sub>R</sub>-U RUPTURE DISK

Designed for use in union type threaded holder, type UR-2 safety head, with thread connections ½, ¾ or 1 inch (13, 19 or 25 mm) all utilizing a nominal 1 inch (25 mm) rupture disk. Refer to 1 inch SKR disk minimum-maximum burst pressure capability for each material for type SKR-U disks.

## BURST TOLERANCE

Marked Burst Pressure	Burst Tolerance
≤ 40 psig (2.76 barg)	± 2 psig (0.138 barg)
> 40 psig (2.76 barg)	± 5%

## FEATURES

- The first rupture disk specifically developed and performance flow tested\* for use in all service conditions
- Gas or liquid service
- Long service life in pressure cycling or pulsating conditions
- Suitable for operating pressures up to 90% of the marked burst pressure, or 95% of the minimum burst pressure
- Damage safety ratio < 1
- Designed for non-fragmentation
- Standard MDR: 0%, optional -5%, -10%
- Withstands full vacuum
- Ideal for relief valve isolation
- Three-dimensional tag indicates correct directional orientation and ASME or CE requirements
- US patents 6321582, 6178983, 6446653, 5996605 and international patents apply
- For installation in Types SRI-7RS, SRB-7RS, S90-7R, SRB-7FS, SPR-7R, SR-7R and TR-Series pretorqued safety heads

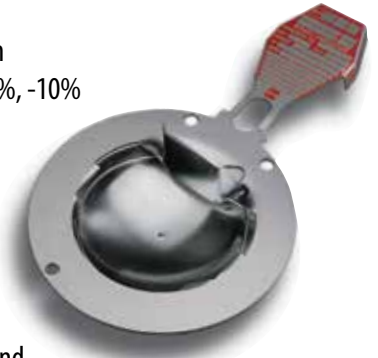

\*ASME code section XIII division 1, according to the test method of PTC-25

## MANUFACTURING DESIGN RANGE (MDR)

The standard MDR for the SKR disk is 0%. The user's requested burst pressure will be the marked burst pressure. Optional MDR's of -5% and -10% may be selected as operating conditions permit. The MDR is applied to the minus side only of the requested burst pressure.

Example: Requested burst pressure 100 psig (6.89 barg). Agreed MDR - 10%. Therefore the marked burst pressure shall be between 90 psig (6.89 barg) and 100 psig (6.89 barg).

## SK<sub>R</sub><sup>TM</sup> Disk Specifications Minimum / Maximum Pressure Rating at 72°F (22°C) PSIG (barg)

Disk Size		Nickel Alloy 200				Monel <sup>®</sup> Alloy 400				Inconel <sup>®</sup> Alloy 600				Hastelloy <sup>®</sup> Alloy C-276 and 316				Tantalum				Titanium			
in	mm	psig		barg		psig		barg		psig		barg		psig		barg		psig		barg		psig		barg	
		Min	Max	Min	Max	Min	Max	Min	Max	Min	Max	Min	Max	Min	Max	Min	Max	Min	Max	Min	Max	Min	Max	Min	Max
0.75	20	55	500	3.79	34.47	60	500	4.14	34.47	60	500	4.14	34.47	60	500	4.14	34.47	55	500	3.79	34.47	90	500	6.20	34.47
1	25	55	500	3.79	34.47	60	500	4.14	34.47	60	500	4.14	34.47	60	500	4.14	34.47	55	500	3.79	34.47	90	500	6.20	34.47
1.5	40	40	500	2.76	34.47	45	500	3.10	34.47	45	500	3.10	34.47	45	500	3.10	34.47	40	500	2.76	34.47	60	500	4.14	34.47
2	50	25	500	1.72	34.47	30	500	2.07	34.47	30	500	2.07	34.47	30	500	2.07	34.47	25	500	1.72	34.47	35	500	2.41	34.47
3	80	20	500	1.38	34.47	22	500	1.52	34.47	22	500	1.52	34.47	25	500	1.72	34.47	20	500	1.38	34.47	25	500	1.72	34.47
4	100	16	500	1.10	34.47	18	500	1.24	34.47	18	500	1.24	34.47	20	500	1.38	34.47	16	500	1.10	34.47	20	500	1.38	34.47
6	150	15	261	1.03	18.00	15	261	1.03	18.00	15	261	1.03	18.00	20	261	1.38	18.00	15	261	1.03	18.00	20	261	1.38	18.00
8	200	15	200	1.03	13.79	15	200	1.03	13.79	15	200	1.03	13.79	20	200	1.38	13.79	15	200	1.03	13.79	20	200	1.38	13.79
10	250	15	150	1.03	10.34	15	150	1.03	10.34	15	150	1.03	10.34	20	150	1.38	10.34	15	150	1.03	10.34	20	150	1.38	10.34
12	300	10	110	0.69	7.58	15	110	1.03	7.58	15	110	1.03	7.58	15	110	1.03	7.58	15	110	1.03	7.58	20	110	1.38	7.58

Larger sizes are available. Consult BS&B. **Note:** Hastelloy<sup>®</sup> is a trademark of Haynes International Inc. Monel<sup>®</sup> and Inconel<sup>®</sup> are registered trademarks of Special Metals Corporation and its subsidiaries.



LPS™  
Rupture Disk



## LPS™ Low Pressure Reverse Buckling Disk

The LPS rupture disk was developed to provide low burst pressures from 5 psig (0.35 barg) using reverse buckling rupture disk technology. The LPS rupture disk, combined with the SRI-7RS® or SRB-7RS® safety heads, provides accuracy and reliability. The LPS uses SAF™ technology enabling very low burst pressures to be achieved with excellent opening characteristics. The Type GLP-S rupture disk is available for installation in the sanitary/aseptic SR-C safety head.

### FEATURES

- Solid metal design
- Low burst pressure from 5 psig (0.35 barg)
- Designed for gas, liquid or two phase service
- Fail safe: damage safety ratio < 1
- Designed for non-fragmentation
- Vacuum and back pressure resistant
- High operating ratio: 90% of minimum burst pressure
- Reverse buckling disk in sizes: 1-12 inches (25-300 mm)
- For installation in Types SRI-7RS and SRB-7RS, S90-7R, SRB-7FS, SPR-7R, SR-7R and TR-Series pretorqued safety heads
- US patents 6178983, 6321582, 6446653, 6494074 and international patents apply
- Sanitary / Aseptic options are available

Note: Hastelloy® is a trademark of Haynes International Inc. Monel® and Inconel® are registered trademarks of Special Metals Corporation and its subsidiaries.

### LPS™ Disk Specifications Minimum / Maximum Pressure with Rating at 72°F (22°C)

Disk Size	Nickel Alloy 200		Monel® Alloy 400				Inconel® Alloy 600				Hastelloy® Alloy C-276				Tantalum				316ss						
	psig		barg		psig		barg		psig		barg		psig		barg		psig		barg		psig		barg		
	in	mm	Min	Max	Min	Max	Min	Max	Min	Max	Min	Max	Min	Max	Min	Max	Min	Max	Min	Max	Min	Max	Min	Max	
1	25	15	70	1.03	4.83	20	70	1.38	4.83	20	70	1.38	4.83	15	70	1.03	4.83	20	70	1.38	4.83	15	70	1.03	4.83
1.5	40	6	55	0.41	3.79	10	55	0.69	3.79	10	55	0.69	3.79	7	55	0.48	3.79	10	55	0.69	3.79	6	55	0.41	3.79
2	50	5	40	0.34	2.76	8	40	0.55	2.76	8	40	0.55	2.76	6	40	0.41	2.76	8	40	0.55	2.76	5	40	0.34	2.76
3	80	5	35	0.34	2.41	7	35	0.48	2.41	7	35	0.48	2.41	5	35	0.34	2.41	7	35	0.48	2.41	5	35	0.34	2.41
4	100	5	30	0.34	2.06	7	30	0.48	2.06	7	30	0.48	2.06	5	30	0.34	2.06	7	30	0.48	2.06	5	30	0.34	2.06
6	150	5	25	0.34	1.72	7	25	0.48	1.72	7	25	0.48	1.72	5	25	0.34	1.72	7	25	0.48	1.72	5	25	0.34	1.72
8	200	5	25	0.34	1.72	7	25	0.48	1.72	7	25	0.48	1.72	5	25	0.34	1.72	7	25	0.48	1.72	5	25	0.34	1.72
10	250	5	25	0.34	1.72	7	25	0.48	1.72	7	25	0.48	1.72	5	25	0.34	1.72	7	25	0.48	1.72	5	25	0.34	1.72
12	300	5	25	0.34	1.72	7	25	0.48	1.72	7	25	0.48	1.72	5	25	0.34	1.72	7	25	0.48	1.72	5	25	0.34	1.72

Refer to previous pages for the maximum recommended temperature and for MNFA/NRA values and SRB-7RS safety head dimensions. Consult BS&B for applications where the disk may be rated with a coincident temperature below 300°F (149°C) (176°F (80°C) for Hastelloy) but operated at a higher value. Special processing may be required.

### MANUFACTURING DESIGN RANGE (MDR)

The standard LPS manufacturing design ranges are 0%, -5%, 10%. For tantalum, the MDR options are -5% and -10% only.

### BURST TOLERANCE

Specified Burst Pressure		Burst Tolerance
psig	barg	
28 and higher	1.93 and higher	±5%
20 to <28	1.38 to <1.93	±7%
10 to <20	0.69 to <1.38	±10%
<10	<0.69	±15%
Alternate: <40	<2.76	± 2psig (0.138barg)

### CYCLE RESISTANCE / TEMPERATURE INFLUENCE / SERVICE LIFE

The cycle resistance of the LPS disk is a function of the application operating conditions. If the operating pressure is static, (without pressure cycles), then, as for all types of rupture disk devices, the service life shall be maximized. If the operating pressure is mildly cyclic, such as the conditions of a sealed atmospheric tank under ambient temperature fluctuations, the LPS disk may resist in excess of 1000 cycles. For more information, review the LPS catalog #77-4002.

### VACUUM RESISTANCE / BACK PRESSURE RESISTANCE

The LPS disk will resist vacuum without the need for an additional vacuum support. Back pressure resistance is limited to 15 psig (1 barg) for disks rated to burst at 15 psig (1 barg) or less. For higher burst pressures, back pressure resistance is equal to the minimum burst pressure of the ordered LPS disk.





# S-90™ Precision Cross-Scored Reverse Buckling Rupture Disk

The S-90 is a domed, solid metal, precision scored reverse buckling disk, which, upon over-pressure, reverses and opens along pre-weakened cross-score lines to provide a full relief opening. The compression loaded S-90 disk offers an extended service life under pressure cycling conditions compared to a conventional tension loaded disk. The S-90 disk exhibits excellent fatigue resistance in cyclic pressure service, surviving 1,000,000 pressure cycles from 0-90% of its marked burst pressure.



## FEATURES

- Designed for non-fragmentation
- Withstands full vacuum and back pressure equal to or less than burst pressure (higher upon request)
- Suitable for operating pressure to 90% of the marked burst pressure and 95% of the minimum burst pressure
- Gas service (acceptable for liquid service with a compressible gas / vapor pocket between the liquid and disk)
- Damage safety ratio 1.5. An S-90 disk damaged or installed incorrectly will burst at or below 1.5 times its marked burst pressure
- Reversal safety ratio equal to or less than 1.5. An S-90 disk and safety head installed upside down in the pressure system will burst at 1.5 times its marked burst pressure or less
- Optimum fatigue resistance in pressure pulsating or cycling conditions
- Ideal for safety relief valve isolation
- Inconel® material has the lowest published KR (gas) of 0.232
- Optional fluoropolymer liners to enhance corrosion resistance on the inlet (process) and / or down-stream side of the disk
- For installation in Types SRI-7RS, SRB-7RS, SRB-7FS, S90-7R, SPR-7R, SR-7R and TR-Series safety heads

*Note: Hastelloy® is a trademark of Haynes International Inc. Monel® and Inconel® are registered trademarks of Special Metals Corporation and its subsidiaries.*

## MANUFACTURING DESIGN RANGE (MDR)

The standard MDR for the S-90 disk is 0%. The user's requested burst pressure will be the marked burst pressure. Optional MDR's of -5% and -10% may be selected as operating conditions permit. The MDR is applied to the minus side only of the requested burst pressure.

## BURST TOLERANCE

Marked Burst Pressure	Burst Tolerance
≤ 40 psig (2.76 barg)	± 2 psig (0.138 barg)
> 40 psig (2.76 barg)	± 5%

## S-90™ Disk Specifications Minimum / Maximum Pressure Rating at 72°F (22°C)

Disk Size		Nickel Alloy 200				Monel® Alloy 400				Hastelloy® Alloy C-276 and 316ss				Inconel® Alloy 600				Aluminum			
in	mm	psig		barg		psig		barg		psig		barg		psig		barg		psig		barg	
		Min	Max	Min	Max	Min	Max	Min	Max	Min	Max	Min	Max	Min	Max	Min	Max	Min	Max	Min	Max
1	25	125	1000	8.62	68.95	150	1000	10.3	68.95	328	1000	22.60	68.95	150	1000	10.3	68.95	75	125	5.17	8.61
1.5	40	90	1000	6.21	68.95	110	1000	7.58	68.95	282	1000	19.40	68.95	110	1000	7.58	68.95	54	90	3.72	6.20
2	50	75	1000	5.17	68.95	90	1000	6.21	68.95	230	1000	15.90	68.95	90	1000	6.21	68.95	45	75	3.10	5.17
3	80	60	1000	4.14	68.95	72	1000	4.96	68.95	167	1000	11.50	68.95	72	1000	4.96	68.95	36	60	2.48	4.14
4	100	50	800	3.45	55.20	60	800	4.14	55.16	132	800	9.10	55.16	60	800	4.14	55.16	30	50	2.06	3.45
6	150	40	800	2.76	55.20	48	800	3.31	55.16	92	800	6.34	55.16	48	800	3.31	55.16	24	40	1.65	2.76
8	200	35	700	2.41	48.30	42	700	2.89	48.26	42	700	2.89	48.26	42	700	2.89	48.26	-	-	-	-
10	250	30	700	2.07	48.30	36	700	2.48	48.26	36	700	2.48	48.26	36	700	2.48	48.26	-	-	-	-
12	300	27	600	1.87	41.40	33	600	2.28	41.37	33	600	2.28	41.37	33	600	2.28	41.37	-	-	-	-
14	350	25	500	1.72	34.50	30	500	2.07	34.47	30	500	2.07	34.47	30	500	2.07	34.47	-	-	-	-
16	400	23	100	1.59	6.89	28	475	1.93	32.75	28	475	1.93	32.75	28	475	1.93	32.75	-	-	-	-
18	450	22	92	1.52	6.34	26	475	1.79	32.75	26	475	1.79	32.75	26	475	1.79	32.75	-	-	-	-
20	500	21	84	1.45	5.79	24	250	1.65	17.24	24	250	1.65	17.24	24	250	1.65	17.24	-	-	-	-
24	600	20	70	1.38	4.83	22	250	1.52	17.24	22	250	1.52	17.24	22	250	1.52	17.24	-	-	-	-
30	750	20	70	1.38	4.83	20	250	1.38	17.24	20	250	1.38	17.24	20	250	1.38	17.24	-	-	-	-
40	1000	20	70	1.38	4.83	20	250	1.38	17.24	20	250	1.38	17.24	20	250	1.38	17.24	-	-	-	-

*Consult BS&B for applications where the disk may be rated with a coincident temperature below 300°F (149°C) (176°F (80°C) for Hastelloy) but operated at a higher value. Special processing may be required.*



## RLS™ Precision Circular-Scored Reverse Buckling Rupture Disk

The RLS is a precision circular-scored reverse buckling rupture disk. When over-pressurized, this domed, solid metal, reverse buckling disk reverses and opens along a pre-weakened circular score line on the down-stream side of the disk. A patented hinge welded to the disk facilitates relief opening along the score line and retains the disk's central petal preventing fragmentation even at high burst pressures.

### BURST TOLERANCE

Marked Burst Pressure	Burst Tolerance
≤ 40 psig (2.76 barg)	± 2 psig (0.138 barg)
> 40 psig (2.76 barg)	± 5%

### FEATURES

- For gas or liquid service
- Designed for non-fragmentation
- Withstands full vacuum
- Suitable for operating pressure to 90% of the marked burst pressure and 95% of the minimum burst pressure (CEN ISO 4126-2 standard pending)
- Damage safety ratio 1.5. A damaged RLS disk will burst at or below 1.5 times its marked burst pressure
- Optimum fatigue resistance in pressure pulsating or cycling conditions
- Recommended for safety relief valve isolation
- Optional fluoropolymer/plastic liners on the process and / or down-stream side of the disk - order as "Fluoropolymer liner" or identify special requirements
- For installation in Types SRI-7RS, SRB-7RS, S90-7R, SRB-7FS, SPR-7R, SR-7R, and TR-Series pretorqued safety heads

### MANUFACTURING DESIGN RANGE (MDR)

The standard MDR for the RLS disk is 0%. The user's requested burst pressure will be the marked burst pressure. Optional MDR's of -5% and -10% may be selected as operating conditions permit. The MDR is applied to the minus side only of the requested burst pressure.

*Note: Hastelloy® is a trademark of Haynes International Inc. Monel® and Inconel® are registered trademarks of Special Metals Corporation and its subsidiaries.*

RLS™ Disk Specifications Minimum / Maximum Pressure with Rating at 72°F (22°C) for Gas, Steam, Liquid and Vapor Openings

Disk Size		Nickel Alloy 200				Monel® Alloy 400				Inconel® Alloy 600				Hastelloy® Alloy C-276 and 316ss				Tantalum			
in	mm	psig		barg		psig		barg		psig		barg		psig		barg		psig		barg	
		Min	Max	Min	Max	Min	Max	Min	Max	Min	Max	Min	Max	Min	Max	Min	Max	Min	Max	Min	Max
1	25	125	2000	8.62	137.90	150	2000		137.90	150	2000	10.34	137.90	175	2000	12.07	137.90	125	2000	8.62	137.90
1.5	40	85	1800	5.86	124.10	105	1800	7.24	124.10	105	1800	7.24	124.10	145	1800	10.00	124.10	85	1800	5.86	124.10
2	50	70	1800	4.83	124.10	85	1800	5.86	124.10	85	1800	5.86	124.10	115	1800	7.93	124.10	70	1800	4.83	124.10
3	80	55	1600	3.79	110.32	65	1600	4.48	110.32	65	1600	4.48	110.32	75	1600	5.17	110.32	55	1600	3.79	110.32
4	100	45	1050	3.10	72.39	55	1050	3.79	72.39	55	1050	3.79	72.39	65	1050	4.48	72.39	45	1050	3.10	72.39
6	150	35	650	2.41	44.82	40	650	2.76	44.82	40	650	2.76	44.82	45	650	3.10	44.82	35	650	2.41	44.82
8	200	35	400	2.41	27.58	40	400	2.76	27.58	40	400	2.76	27.58	45	400	3.10	27.58	-	-	-	-
10	250	35	250	2.41	17.24	40	250	2.76	17.24	40	250	2.76	17.24	45	250	3.10	17.24	-	-	-	-
12	300	35	150	2.41	10.34	40	150	2.76	10.34	40	150	2.76	10.34	45	150	3.10	10.34	-	-	-	-
14	350	35	130	2.41	8.96	40	130	2.76	8.96	40	130	2.76	8.96	45	130	3.10	8.96	-	-	-	-
16	400	25	110	1.72	7.58	30	110	2.07	7.58	30	110	2.07	7.58	35	110	2.41	7.58	-	-	-	-
18	450	25	90	1.72	6.21	30	90	2.07	6.21	30	90	2.07	6.21	35	90	2.41	6.21	-	-	-	-
20	500	20	75	1.38	5.17	20	75	1.38	5.17	20	75	1.38	5.17	20	75	1.38	5.17	-	-	-	-

The hinge attached to the disk is 316ss. Fluoropolymer liners available at all burst pressures. For burst pressures below RLS minimums use JRS, FRS, SKR, Sigma or S-90 type disks



# JRS™ Solid Metal Reverse Buckling Rupture Disk

A domed, solid metal low-pressure reverse buckling disk, the JRS reverses on over-pressure and opens by cutting along a teeth ring attached to the atmospheric side of the disk. A hinge integral to the teeth ring on the downstream side of the disk retains the disk's central petal preventing fragmentation.



## FEATURES

- Designed for non-fragmentation and withstands full vacuum
- Suitable for operating pressure to 90% of the marked burst pressure or 95% of the minimum burst pressure (CEN ISO 4126-2 standard pending)
- Suitable for operating pressure of 90% of the minimum burst pressure for burst pressures below 40 psi (2.76 barg)
- Gas service (acceptable for liquid service with a compressible gas/vapor pocket between the liquid and disk)
- Recommended for safety relief valve isolation
- Damage safety ratio 1.5. A damaged JRS disk will burst at or below 1.5 times its marked burst pressure
- Fatigue resistance in pressure pulsating or cycling conditions
- Optional fluoropolymer / plastic liner on disk process side
- For installation in Types SRI-7RS, SRB-7RS, SRB-7FS and TR-Series safety heads

## MANUFACTURING DESIGN RANGE (MDR)

The standard MDR for the JRS disk is 0%. The user's requested burst pressure will be the marked burst pressure. Optional MDR's of -5% and -10% may be selected as operating conditions permit. The MDR is applied to the minus side only of the requested burst pressure.

## BURST TOLERANCE

Marked Burst Pressure	Burst Tolerance
≤ 40 psig (2.76 barg)	± 2 psig (0.138 barg)
> 40 psig (2.76 barg)	± 5%

## JRS™ Disk Specifications Min / Max Pressure Rating at 72°F (22°C)

Disk Size		Nickel Alloy 200				Monel® Alloy 400				Inconel® Alloy 600				Hastelloy® Alloy C-276				316ss			
in	mm	psig		barg		psig		barg		psig		barg		psig		barg		psig		barg	
		Min	Max	Min	Max	Min	Max	Min	Max	Min	Max	Min	Max	Min	Max	Min	Max	Min	Max	Min	Max
1	25	22	125	1.52	8.62	22	150	1.52	10.34	22	150	1.52	10.34	24	180	1.65	12.41	24	180	1.65	12.41
1.5	40	20	90	1.38	6.21	20	110	1.38	7.58	20	110	1.38	7.58	22	150	1.52	10.34	22	150	1.52	10.34
2	50	18	75	1.24	5.17	18	90	1.24	6.21	18	90	1.24	6.21	20	120	1.38	8.27	20	120	1.38	8.27
3	80	16	60	1.10	4.14	16	72	1.10	4.96	16	72	1.10	4.96	18	80	1.24	5.52	18	80	1.24	5.52
4	100	14	50	0.97	3.45	14	60	0.97	4.14	14	60	0.97	4.14	16	70	1.10	4.83	16	70	1.10	4.83
6	150	12	40	0.83	2.76	12	48	0.83	3.31	12	48	0.83	3.31	14	50	0.97	3.45	14	50	0.97	3.45
8	200	12	35	0.83	2.41	12	42	0.83	2.89	12	42	0.83	2.89	12	42	0.83	2.89	12	42	0.83	2.89
10	250	12	30	0.83	2.07	12	36	0.83	2.48	12	36	0.83	2.48	12	36	0.83	2.48	12	36	0.83	2.48
12	300	12	27	0.62	1.86	12	33	0.62	2.28	12	33	0.62	2.28	12	33	0.83	2.28	12	33	0.83	2.28
14	350	9	25	0.48	1.72	9	30	0.48	2.07	9	30	0.48	2.07	9	30	0.62	2.07	9	30	0.62	2.07
16	400	7	23	0.41	1.59	7	28	0.41	1.93	7	28	0.41	1.93	7	28	0.48	1.93	7	28	0.48	1.93
18	450	6	22	0.34	1.52	6	26	0.34	1.79	6	26	0.34	1.79	6	26	0.41	1.79	6	26	0.41	1.79
20	500	5	21	0.34	1.45	5	24	0.34	1.65	5	24	0.34	1.65	5	24	0.34	1.65	5	24	0.34	1.65
24	600	5	19	0.34	1.31	5	22	0.34	1.52	5	22	0.34	1.52	5	22	0.34	1.52	5	22	0.34	1.52
30	750	5	12	0.34	0.83	5	14	0.34	0.97	5	14	0.34	0.97	5	14	0.34	0.97	5	14	0.34	0.97
36	900	5	12	0.34	0.83	5	14	0.34	0.97	5	14	0.34	0.97	5	14	0.34	0.97	5	14	0.34	0.97
40	1000	5	10	0.34	0.69	5	12	0.34	0.83	5	12	0.34	0.83	5	12	0.34	0.83	5	12	0.34	0.83
42	1050	5	10	0.34	0.69	5	12	0.34	0.83	5	12	0.34	0.83	5	12	0.34	0.83	5	12	0.34	0.83

Minimum burst pressures are applicable at all temperatures; maximum burst pressures at 72 °F (22°C). For burst pressures below JRS minimums use the type FRS or type LPS disk. For pressures above the JRS maximums, use disk types S-90, RLS, SKR and Sigma. Note: Hastelloy® is a trademark of Haynes International Inc. Monel® and Inconel® are registered trademarks of Special Metals Corporation and its subsidiaries.





# SRD™ and SRD-L™

## Precision Circular-Scored Reverse Buckling Rupture Disk

The SRD and SRD-L (for lower burst pressures) are precision circular-scored reverse buckling rupture disks. When over-pressurized, the domed, solid metal, reverse buckling disks reverse and open along a pre-weakened circular score lines on the down-stream side of the disks. A patented hinge welded to the disk facilitates relief opening along the score line and retains the disk's central petal preventing fragmentation even at high burst pressures.



SRD™ Scored Reverse Buckling Rupture Disk

SRD-L™ Scored Reverse Buckling Rupture Disk (Lower Burst Pressures)

### MANUFACTURING DESIGN RANGE (MDR)

The standard MDR for the SRD disk is 0%. The user's requested burst pressure will be the marked burst pressure. Optional MDR's of -5% and -10% may be selected as operating conditions permit. The MDR is applied to the minus side only of the requested burst pressure.



Activated SRD™

### FEATURES

- For gas or liquid service
- Designed for non-fragmentation
- Withstands full vacuum
- Suitable for operating pressure to 90% of the marked burst pressure and 95% of the minimum burst pressure (CEN ISO 4126-2 standard pending)
- Damage safety ratio 1.5. A damaged SRD and SRD-L disk will burst at or below 1.5 times its marked burst pressure
- Optimum fatigue resistance in pressure pulsating or cycling conditions
- Recommended for safety relief valve isolation
- Optional fluoropolymer/plastic liners on the process and/or down-stream side of the disk
- For installation in Types SRI-7RS, SRB-7RS, SRB-7FS, S90-7R, SPR-7R, SR-7R, and TR-Series safety heads

### BURST TOLERANCE

Marked Burst Pressure	Burst Tolerance
≤ 40 psig (2.76 barg)	± 2 psig (0.138 barg)
> 40 psig (2.76 barg)	± 5%

### SRD™ Disk Specifications Minimum / Maximum Pressure with Rating at 72°F (22°C)

Disk Size		SRD				SRD-L				Material
in	mm	psig		barg		psig		barg		
		Min	Max	Min	Max	Min	Max	Min	Max	
1	25	481	750	33.2	51.7	75	480	5.2	33.1	Tantalum, Nickel Alloy 200, Hastelloy® Alloy C-276 and 316ss, Inconel® Alloy 600, Monel® Alloy 400, and Titanium
1.5	40	421	600	29.0	41.4	75	420	5.2	29.0	
2	50	421	500	29.0	34.5	75	420	5.2	29.0	
3	80	281	500	19.4	34.5	45	280	3.1	19.4	
4	100	271	500	18.7	34.5	20	270	1.4	18.7	
6	150	101	200	7.0	13.8	20	100	1.4	7.0	
8	200	76	150	5.2	10.3	15	75	1.0	5.2	
10	250	60	100	4.1	6.89	13	60	0.9	4.1	
12	300	45	75	3.1	5.17	11	45	0.76	3.10	

The hinge attached to the disk is 316ss. Fluoropolymer liners are available at all burst pressures and may be applied to either side or both sides of a SRD or SRD-L Rupture Disk. Liners may not be available for all burst pressures shown.

**Note:** Hastelloy® is a trademark of Haynes International Inc. Monel® and Inconel® are registered trademarks of Special Metals Corporation and its subsidiaries.



## FRS™ and FRL™

### Precision Circular-Scored Reverse Buckling Rupture Disk

A domed, low-pressure frustum-shaped, reverse buckling disk, the FRS and FRL reverse on overpressure and opens along a pre-weakened circular score line on the downstream side of the disk. The circular score line has an interrupted “hinge” segment which retains the disk’s central petal and prevents fragmentation.

#### BURST TOLERANCE

Marked Burst Pressure	Burst Tolerance
≤ 40 psig (2.76 barg)	± 2 psig (0.138 barg)
> 40 psig (2.76 barg)	± 5%

#### FEATURES

- Gas or liquid service - order as FRS for gas or gas driven liquid service, or FRL for full liquid service
- Designed for non-fragmentation
- Withstands full vacuum
- Suitable for operating ratio to 95% of the minimum burst pressure
- Damage safety ratio of 1 or less. A damaged disk will burst at its marked burst pressure or lower
- Recommended for safety relief valve isolation
- Optional fluoropolymer liner on the process or downstream side of the disk
- Standard 0% MDR; optional -5% and -10% MDR
- For installation in Types SRI-7RS, SRB-7RS, S90-7R, SRB-7FS and TR-Series safety heads

#### FRS™ FRL™ Disk Specifications Min/Max Pressure Rating at 72°F (22°C)

Available materials: 316 Stainless Steel ; Nickel (alloy 200); Inconel (alloy 600); and Monel (alloy 400). Other materials available upon request.

Disk Size		Burst Pressure			
		Min		Max	
in	mm	psig	barg	psig	barg
1	25	13.5 (36)	0.93 (2.48)	150	10.34
1.5	40	11.5 (16)	0.79 (1.10)	70	4.83
2	50	11.5 (14)	0.79 (0.97)	50	3.45

Pressures in parenthesis are with fluoropolymer liners

**Note:** Hastelloy® is a trademark of Haynes International Inc. Monel® and Inconel® are registered trademarks of Special Metals Corporation and its subsidiaries.

## Burst Alert™ Sensors

Burst Alert Sensors are installed downstream of the Rupture Disk device and provide a convenient means of generating an electrical signal when appropriately integrated into plant control systems, or connected to the BS&B Safety Systems Burst Disk Monitor. The Burst Alert Sensor is a “membrane switch” that changes from closed circuit to open circuit when the upstream Rupture Disk (or relief valve) opens. Consult BS&B for proper sensor selection and specification. Refer to catalog 77-1010 for more information.





# Safety Heads for Sta-Saf®

## Reverse Buckling Disks

Pretorqued safety head technology provides superior performance for demanding applications and has become the user-preferred technology since its invention by BS&B in 1975, now often selected for all applications. The features of all pretorqued safety heads that drive this user preference are:

- Enhanced leak tightness; pretorqued cap-screws energize the seal between the rupture disk and safety head, minimizing reliance on companion flange stud torque to ensure proper sealing.
- Simple modular installation of pressure relief device; designed to be assembled in a controlled workshop environment with the rupture disk & safety head assembly then brought to the point of installation as a modular unit. (Both ASME and EN Standards define the combination of a rupture disk & safety head as the pressure relief device.)
- Inspection capability; while the rupture disk and safety head remain combined, the device may be removed from service for inspection and reinstalled provided the pretorqued cap-screws remain secure.
- Interchangeability; all of BS&B's pretorqued safety heads for reverse buckling disks allow 11 high performance rupture disk models to be installed, covering the burst pressure range from 5psi to 6000psi (0.345 bar to 413.6 bar) with all international flange standards accommodated. A single safety head may be purposed for multiple application conditions, allowing upgrade of rupture disk technology deployed all the way up to Sigma EXL when operating conditions require.

## Torque Resistant Safety Head Option Type TR™

For applications where safety head installation between companion flanges will use high energy sealing systems such as spiral wound gaskets, the Torque Resistant safety head option is recommended. All of the Sta-Saf pretorqued safety heads can be provided in the TR™ option which provides an enlarged internal seating surface to distribute higher companion flange loads to seat the rupture disk correctly.

When the TR™ option is selected, the safety head model names become:

- SRI-7RS-TR
- SRB-7RS-TR
- SRB-7FS-TR

The TR™ option safety head may be applied with standard companion flange sealing systems such as compressed fiber gaskets.

*Note: Always follow BS&B installation instructions.*

# SRI-7RS™, SRB-7RS™ and SRB-7FS™

## Pretorqued Safety Heads

### FEATURES

- Pretorqued capscrews or bolts to energize the seal between the rupture disk and safety head, independent of companion flange bolt arrangement
- Three asymmetric locating pins center the rupture disk within the safety head, which optimizes flow
- Locating pins arranged to ensure proper directional orientation of the rupture disk installation
- Rupture disk dome fully protected within safety head inlet to avoid damage when installed into piping system
- Proprietary 'bite seal' to optimize sealing between rupture disk and safety head process side. Standard for nominal size 2 inch (50mm) and larger
- Spiral gasket surface on inlet and outlet extend mating surface to enhance companion flange gasket performance\*

*\*ASME/ANSI B16-5 gasket sealing surface is standard*

### STANDARD MATERIALS

316 stainless steel and carbon steel. Also available Monel® alloy 400, Inconel® alloy 600, Hastelloy® alloy C and C-276, 316L stainless steel and titanium.

#### Rupture Disk Types for Use in SRI-7RS, SRB-7RS and SRB-7FS Safety Heads

- |                   |        |         |
|-------------------|--------|---------|
| • Sigma           | • S-90 | • RLS   |
| • Sigma EXL       | • JRS  | • SRD   |
| • SK <sub>R</sub> | • FRS  | • SRD-L |
| • LPS             | • FRL  |         |

*Note: Hastelloy® is a trademark of Haynes International Inc. Monel® and Inconel® are registered trademarks of Special Metals Corporation and its subsidiaries.*



# SRI-7RS™

In the spirit of BS&B's core values of Innovation and Excellence, the SRI-7RS has been developed to enhance and optimize safety, reliability, convenience, and performance. The experience gained from meeting and exceeding customer expectations with the SRB-7RS safety head is built upon by the following SRI-7RS features:

- Bite seal in all sizes; proprietary feature which enhances leak tightness
- Light weight; manufactured from a casting, the SRI-7RS takes advantage of advanced metal flow modeling to achieve its light construction and rigid strength
- Self centering; the unique perimeter shape of the SRI-7RS is self centering between ASME / ANSI B16.5, EN, and JIS specification companion flanges, optimizing flow
- Hexagon head pretorqued capscrews; supplied with the SRI-7RS safety head, high tensile stainless steel capscrews allow installation using standard workshop tools. companion flanges, the user can conveniently inspect for proper installation
- Multiple flange rating; each nominal size SRI-7RS safety head can be installed between ASME/ANSI B16.5, EN, JIS (except 3" / 80mm and 4" / 100mm JIS10) companion flanges. A single safety head held in inventory per nominal size will support multiple applications

*Note: The SRI-7RS safety head is US & International Patent Pending.*



Size		Safety Head Flange Rating			Safety Head Flange Thickness	
in	mm	ASME / ANSI	EN	JIS	in	mm
1	25	150/300/600	10/16/25/40	10/16/20/30/40	1.5	38
1.5	40	150/300/600	10/16/25/40	10/16/20/30/40	1.7	43
2	50	150/300/600	10/16/25/40	10/16/20/30/40	1.9	48
3	80	150/300/600	10/16/25/40	16/20/30/40	2.2	55
4	100	150/300*	10/16/25/40	16/20/30/40	2.9	73
6	150	150/300*	10/16/25/40	10/16/20/30	3.6	92
8	200	150/300*	10/16/25/40	16/20/30	3.8	95

*\* Available for ANSI 600# with adapter ring. Consult BS&B or your local representative.*

## FLANGE BOLT PATTERNS

ANSI / ASME B16.5 150lb configurations shown.

1" (DN 25) SRI-7RS  
1.5" (DN 40) SRI-7RS



2" (DN 50) SRI-7RS  
3" (DN 80) SRI-7RS\*



4" (DN 100) SRI-7RS\*



6" (DN 150) SRI-7RS  
8" (DN 150) SRI-7RS

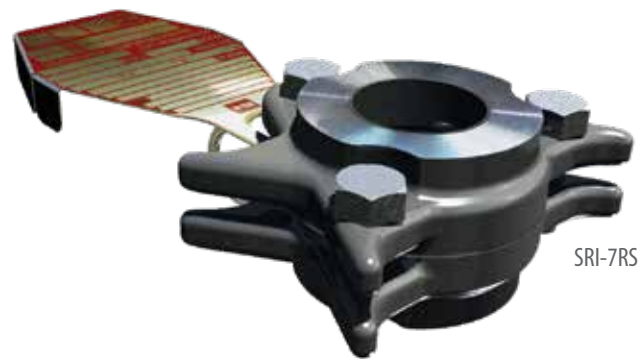

SRI-7RS



# SRB-7RS™

## Pretorqued Insert Safety Head

The SRB-7RS is the industry standard pretorqued holder which ensures proper clamping of a rupture disk before installation between companion flanges.

The SRB-7RS locates inside the studs between two companion flanges, typically referred to as 'insert type' installation. A J-bolt ensures the safety head is fitted in the required direction between companion flanges by engaging a blind hole drilled on the inlet companion flange perimeter. The J-bolt provides a constant visible signal of correct installation.

Fluoropolymer coated high tensile carbon steel cap screws (blue color) are provided as standard. Alternative cap screw materials are available upon request.

The SRB-7RS is designed for well centered installation inside the companion flange bolt circle of a wide range of flange types and ratings including ASME/ANSI, EN, and JIS.

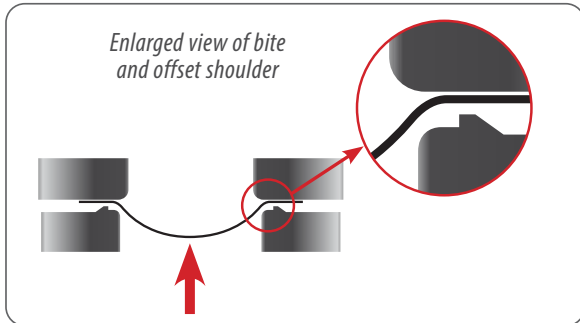

SRB-7RS safety head (Pretorqued design)



SRB-7RS™ safety head installed between companion flange

## SRB-7RS™ Safety Head Dimensions

Size		Safety Head Flange Rating			Face-to-Face Dimensions	
in	mm	ASME / ANSI	EN/DIN	JIS	in	mm
1	25	150	10/16	10/16	1.480	38
1	25	300/600	25/40	20/30/40	1.480	38
1	25	900/1500	-	-	3.000	76
1.5	40	150	10/16	10/16	1.680	43
1.5	40	300/600	25/40	20/30/40	1.680	43
1.5	40	900/1500	-	-	2.600	66
2	50	150	10/16	10/16	1.880	48
2	50	300/600	25/40	20/30/40	1.880	48
2	50	900/1500	-	-	3.375	85
3	80	150	10/16	10/16	2.170	55
3	80	300/600	25/40	20/30/40	2.170	55
3	80	900	-	-	3.500	89
4	100	150	10/16	10/16	2.880	73
4	100	300	25/40	20/30/40	2.880	73
4	100	600	-	-	2.500	67
6	150	150	10/16	10/16	3.624	92
6	150	300	25/40	20/30/40	3.624	92
6	150	600	-	-	3.062	79
8	200	150	-	-	3.750	95
8	200	300	-	-	3.750	95
10	250	150	-	-	4.313	109
10	250	300	-	-	4.313	109
12	300	150	-	-	4.625	117
12	300	300	-	-	5.250	133
14	350	150	-	-	5.250	133
14	350	300	-	-	5.875	149
16	400	150	-	-	6.375	162
16	400	300	-	-	7.125	181
18	450	150	-	-	7.375	187
18	450	300	-	-	7.875	200
20	500	150	-	-	8.437	214
20	500	300	-	-	8.625	219
24	600	150	-	-	10.250	260
24	600	300	-	-	10.750	273
30*	750	-	-	-	12.000	305
36*	900	-	-	-	15.000	381

\*Applicable to ASME B16 47 Series A

Contact BS&B for other sizes, ratings, or face-to-face dimensions.



# SRB-7FS™

## Pre-Torqued Full-Bolted Safety Head

A full-bolted option sharing the design features of the type SRB-7RS safety head. The type SRB-7FS safety head installs between companion flanges with the studs passing through bolt holes in the perimeter of the holder. This full bolted design may be used with ring type joint (RTJ) companion flange connections.

The SRB-7FS allows for proper centering, especially within horizontal piping. The design of the SRB-7RS allows its studs to be protected from external fires within could cause loss of containment. This design also allows the studs to be protected from the environment (help reduced rust, corrosion, etc.) and protects the stud threads from damage.

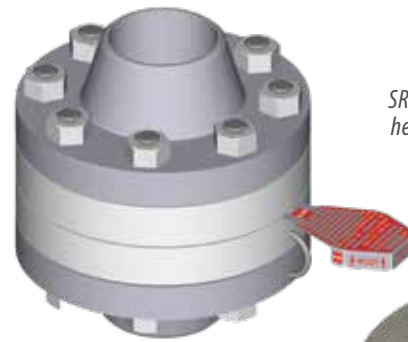

*SRB-7FS™ pre-torqued safety head installed between weld neck companion flanges*



# TR™ Series

## Torque Resistant Safety Head Option

The Type TR™ Series torque resistant safety head option offers the identical performance and flow characteristics valued from standard BS&B safety heads. The only difference – the TR Series Safety Heads are designed with a wider seating surface to be used with metal spiral wound gaskets at the flange. This distinct safety feature protects rupture disks from situations where plant personnel may overtorque rupture disks within piping systems.

Because of the wider seating surface of the TR Series Safety Head, the load is distributed over a much broader area reducing the influence of excessive torque transmitted to the disk.

### AVAILABLE SAFETY HEADS

The TR-Series Torque resistant option is available for the SRB-7RS, SRB-7FS, and S90-7R. Order by adding “TR”:

- SRB-7RS-TR
- S90-7R-TR
- SRB-7FS-TR

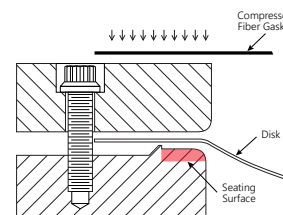

*SRB-7RS Safety Head*

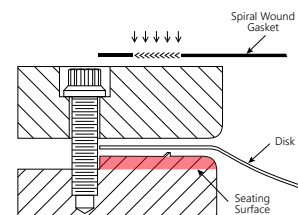

*SRB-7RS-TR Series Safety Head*



# Double Disk Assemblies

Double disk assemblies consist of three safety head components; an inlet, a mid-flange and an outlet with a disk installed between the inlet and mid-flange. A second disk is installed between the mid-flange and outlet flange. All Sta-Saf safety heads models are available as double disk assemblies.

## APPLICATIONS

1. Increased safety - implementation of a second barrier to corrosion or mechanical perforation. The first rupture disk (upstream) is backed up by the second rupture disk (downstream) which allows for the generation of an alarm by the code required monitoring device such as a tell-tale assembly (shown). Maintenance replacement can be planned since loss of process fluid has been conserved by the second (downstream) rupture disk.
2. Management of back pressure - the first (upstream) rupture disk will activate when the process fluid pressure reaches the selected burst pressure independent of backpressure effects. The second (downstream) rupture disk isolates the first disk from backpressure. The space between the two rupture disks is maintained at atmospheric pressure, allowing the first rupture disk to respond to process fluid pressure only.
3. Quick opening valve - the first (upstream) rupture disk is maintained at a controlled back pressure of a value below the set pressure of the second (downstream) rupture disk. When a customer specified condition occurs in the system, both rupture disks can be actuated on demand by releasing the controlled backpressure.

Double disk assemblies are available with the TR™ torque resistant option.

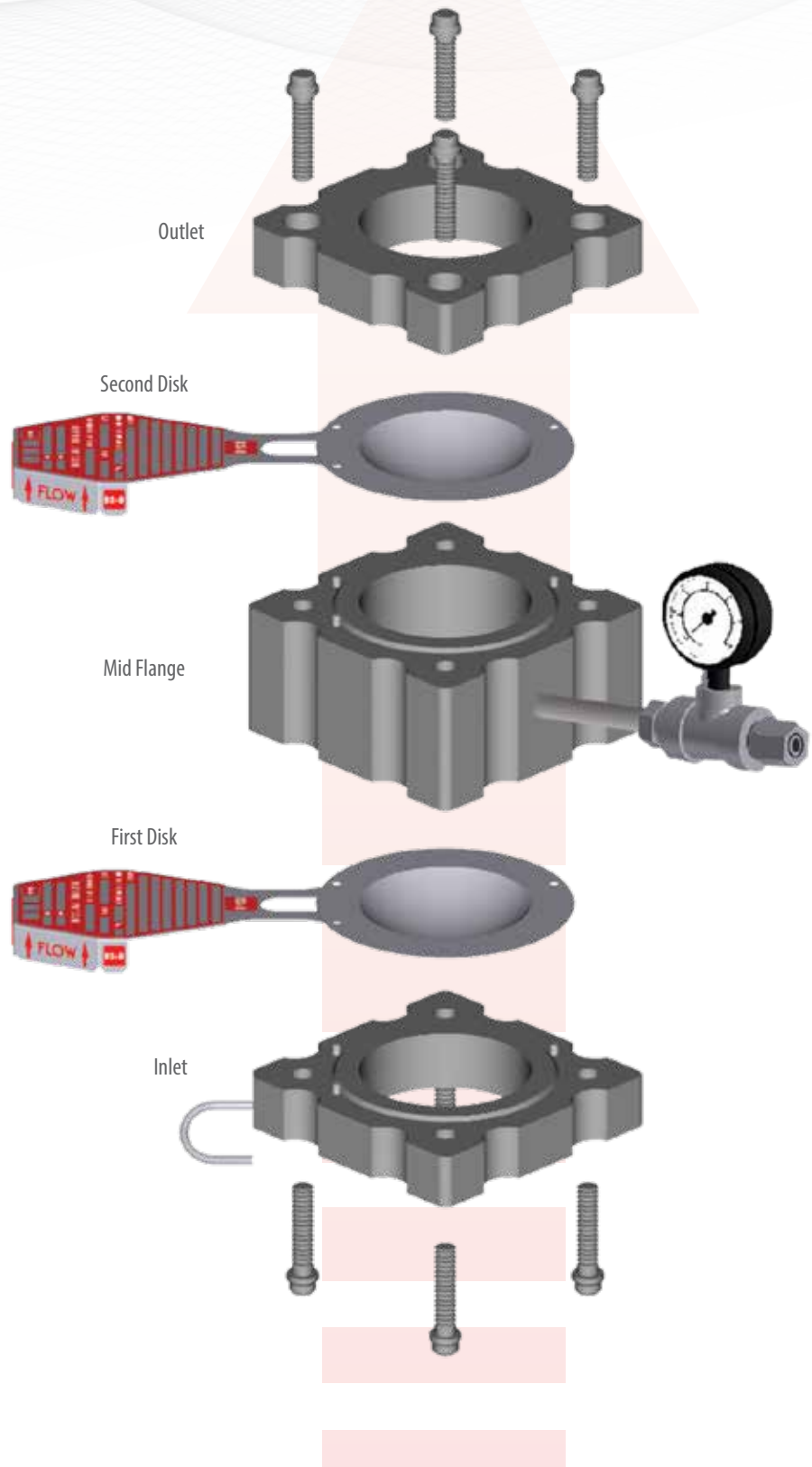

Type SRB-7RS™ Double Disk Assembly

# S90-7R™ Pre-

## Assembled Insert Safety Head

The S90-7R™ locates inside the studs between two companion flanges. Pre-Assembled safety heads provide for placement of a rupture disk within its holder before presentation to the installation point. Companion flange conditions, including parallelism and bolt torque loading determine the sealing of the rupture disk within the safety head and can influence disk function. Ensure BS&B installation instructions are followed.



Rupture disk types for use in the S90-7R™ safety head:

- Sigma, Sigma EXL
- SKR
- LPS over 15 psig (1barg)
- S-90
- RLS
- FRS
- FRL
- SRD
- SRD-L over 15psig (1barg)

S90-7R-TR™ torque resistant option available.

## S90-7R™ Safety Head Dimensions

Size		Safety Head Flange Rating			Face-to-Face Dimensions	
in	mm	ANSI	DIN	JIS	in	mm
1	25	150	10/16	10/16	1.250	31.75
1	25	300/600	25/40	20/30/40	1.250	31.75
1	25	900/1500	*	*	1.750	31.75
1.5	40	150	10/16	10/16	1.250	31.75
1.5	40	300/600	25/40	20/30/40	1.250	31.75
1.5	40	900/1500	*	*	1.440	36.58
2	50	150	10/16	10/16	1.250	31.75
2	50	300/600	25/40	20/30/40	1.250	31.75
2	50	900/1500	*	*	1.625	41.15
3	80	150	10/16	10/16	1.410	34.95
3	80	300/600	25/40	20/30/40	1.500	38.10
3	80	900	*	*	1.750	44.45
4	100	150	10/16	10/16	1.720	43.66
4	100	300	25/40	20/30/40	1.720	43.66
4	100	600	*	*	1.720	43.66
6	150	150	10/16	10/16	2.500	63.50
6	150	300	25/40	20/30/40	2.500	63.50
6	150	600	*	*	3.125	79.37
8	200	150	*	*	3.375	85.73
8	200	300	*	*	3.375	85.73
10	250	150	*	*	6.000	152.40
10	250	300	*	*	6.000	152.40
12	300	150	*	*	4.560	144.48
12	300	300	*	*	5.500	139.70
14	350	150	*	*	5.625	142.88
14	350	300	*	*	5.625	142.88
16	400	150	*	*	6.375	161.93
16	400	300	*	*	7.125	180.98
18	450	150	*	*	7.500	190.50
18	450	300	*	*	7.500	190.50
20	500	150	*	*	6.250	158.75
20	500	300	*	*	8.625	219.08
24	600	150	*	*	7.000	177.80
24	600	300	*	*	7.750	196.85
30*	750	-	*	*	12.000	304.80
36*	900	-	*	*	15.000	381.00

\*Applicable to ASME Series A

Contact BS&B for other sizes, ratings, or face-to-face dimensions.



## AMERICAS

### Tulsa, OK USA

T: +1 918 622 5950  
F: +1 918 665 3904  
E: sales@bsbsystems.com

### Houston, TX USA

T: +1 713 682 4515  
F: +1 713 682 5992  
E: sales@bsbsystems.com

### Minneapolis, MN USA

T: +1 952 941 0146  
F: +1 952 941 0646  
E: sales@bsbipd.com

### Edmonton, AB Canada

T: +1 780 955 2888  
F: +1 780 955 3975  
E: contacts@bsbprocess.com

### Monterrey, Mexico

T: +011 52 81 8299 5861  
T: +011 52 81 8299 5862  
E: sales@bsbsystems.com

### Sao Paulo, Brasil

T: +55 11 2084 4800  
F: +55 11 2021 3801  
E: sales@bsbbrasil.com

## EUROPE, MIDDLE EAST & AFRICA

### Limerick, Ireland

T: +353 61 484700  
F: +353 61 304774  
E: sales@bsb.ie

### Düsseldorf, Germany

T: +49 211 930550  
F: +49 211 3982171  
E: info@bormann-neupertbsb.de

### Manchester, UK

T: +44 161 955 4202  
F: +44 161 870 1086  
E: sales@bsb-systems.co.uk

### The Hague, The Netherlands

T: +31 20 399 9965  
E: info@bsbsystems.nl

### Copenhagen, Denmark

T: +45 29 65 69 61  
E: info@bsbsystems.dk

### United Arab Emirates

T: +971 (0) 55 518 0314  
T: +971 (0) 55 518 0916  
F: +971 (0) 2 558 9961  
E: sales@bsbsystems.ae

## ASIA PACIFIC

### Singapore

T: +65 6513 9780  
F: +65 6484 3711  
E: sales@bsb.com.sg

### Yokohama, Japan

T: +81 45 450 1271  
F: +81 45 451 3061  
E: information@bsb-systems.co.jp

### Seoul, South Korea

T: +82 2 2636 9110  
F: +82 2 2636 9120  
E: sales@bsbsystems.kr

### Shanghai, China

T: +86 21 6391 2299  
F: +86 21 6391 2117  
E: sales@bsbsystems.com

### Chennai, India

T: +91 44 2450 4200  
F: +91 44 2450 1056  
E: sales@bsbsystems.com



*Visit our website for the most complete, up-to-date information*

*Products, specifications and all data in this literature are subject to change without notice. Questions regarding product selection and specifications for specific applications should be directed to BS&B. All sales are subject to the BS&B companies' standard terms and conditions of sale. Nothing herein should be construed as a warranty of merchantability or fitness for a particular purpose.*

**www.bsbsystems.com | www.bsb.ie**

© 2018 BS&B Innovations, Limited. Updated Nov 2024.