



FLAME ARRESTER
931-B 1/2(3/8)-5x0,2/D
INSTRUCTIONS FOR OPERATING AND MAINTENANCE

REV 1.0

Page 1/4

For the flame arrester type 931-B 1/2(3/8)-5x0,2/D dimension sheet and pressure drop/volume flow diagram are available.

1. Use

The flame arrester type 931-B 1/2(3/8)-5x0,2/D complies with the standard EN ISO 16852:2016 - „Flame Arresters – Performance requirements, test methods and limits for use“.

The general suitability as a detonation flame arrester for stable detonation when used with inflammable gas/air mixture and vapour/air mixture of inflammable liquid of the explosion group IIC (normal gap width < 0,50 mm) has been verified by tests executed at the Institute for Safety Technology IBExU Freiberg. The results of it were confirmed by the issued EC prototype test certificate **IBExU14ATEX2251 X**.

The application of the flame arrester must be according to the safety arrangements of the respective equipment.

On principle, for all cases of use the placement conditions, especially the following limits for the operating pressure and temperature have to be considered:

- maximal permissible operating pressure : 1,2 bar (absolute)
- maximal permissible operating temperature : 60°C

The technical parameters of the flame arrester are documented in the works test certificate according to EN 10204 with the delivery of the device.

In the declaration of compliance it is referred to the accordance with the draft of the harmonised standards EN ISO 16852 and EN 1127-1. The maintenance of the basic safety requirements according to directive 2014/34/EU has been confirmed.

2. Construction

The flame arrester consists of housing (1) with a cover (2) which is fastened by a retaining ring (3).

The outer sealing is carried out by O-ring (12).

In the housing itself there are the flame arresting elements consisting of five metal foil elements (4) and (5) with different directions of winding. The metal foil elements are kept on a distance by a star (6) and a pad (7) und are connected to each other by the screw (9) with a hexagon nut (10). The hexagon nut is secured against loosening by a lock washer (11) and additional to that by an adhesive in the thread.

The inlet and outlet nozzles of the flame arrester have to be locked by means of sealing plug (15) for the protection against impurities and moisture during the transport.

Beside the standard version the housing (1) is equipped with an additional fastening thread M30x1,5.

Created By:	RMG	Date: 01.01.14	BS&B FlameSAF Limited, Limerick, Ireland
Approved By:	D. Hennessy	Date: 01.01.14	



FLAME ARRESTER
931-B 1/2(3/8)-5x0,2/D
INSTRUCTIONS FOR OPERATING AND MAINTENANCE

REV 1.0

Page 2/4

3. Marking

The information for marking the vent is arranged on the nameplate and an additional hazard sign (page 4/4). The following data are indicated:

nameplate

- name and address of the manufacturer
- type (including version number)
- serial number and year of production
- number of the certificate (EC prototype certificate-no.)
- number of relevant standard - ISO 16852
- specific mark for prevention of explosions in connection with the mark indicating the letter "G" (for areas where explosive gas, vapour, air mixtures are available)
- explosion group
- CE mark with the number of the indicated inspection authority, which act during production

Hazard sign

- **Warning Flame arresters have installation and application limits**
Type designation in accordance with ISO 16852
- sign for type of flame arrester: **DET 4** (stable detonation without restriction)
- ratio L_w/D (distance to ignition source): --- (not applicable)
- burn rate „BC“: **c** (no burn time)
- burn time t_{BT} (only for „BC“ b): --- (not applicable)
- explosion group: **IIC**
- operational temperature T_0 : **60°C**
- maximum operational pressure p_0 : **0,12 MPa**

The metal foil element is marked at the outermost wound element, as follows:

- name of the manufacturer
- gap width
- material number
- direction of winding

Example: BS&B-0,2-1.4571-R

4. Installation

The arrangement and the installation of the flame arrester shall be carried out under observance of the applicable rules; especially the instructions for accident prevention have to be maintained.

The connection of the flame arrester into the pipe line is carried out independently from the direction of the starting flame (bi-directional flame arrester).

A vertical as well as a horizontal mounting position is permitted.

The flame arrester shall only be installed in pipelines whose nominal width

- on unprotected side is smaller or equal the connection nominal width of the flame arrester.
- on protected side is not smaller than the nominal width on unprotected side.

Created By:	RMG	Date: 01.01.14	BS&B FlameSAF Limited, Limerick, Ireland
Approved By:	D. Hennessy	Date: 01.01.14	



FLAME ARRESTER
931-B 1/2(3/8)-5x0,2/D
INSTRUCTIONS FOR OPERATING AND MAINTENANCE

REV 1.0

Page 3/4

The standard flame arrester can be mounted into the plant by a pipe clip (outer diameter 45) which is attached to the housing.

The version with an outer fixing thread M30x1,5 can be mounted through this thread.

The flame arrester is equipped with a pipe internal thread Rp according to ISO 7-1 alternatively BSP according to BS 21 or with tapered internal thread NPTF according to ANSI B1.20.3.

For the joint pipe line the suitable tapered outer pipe thread is recommended. If necessary a sealant in the thread may be used (see table1).

For relieving the mounting and dismantling of the flame arrester using a suitable tube fitting is practical.

Table 1: Connecting thread and width across flat 931-B 1/2(3/8)-5x0,2/D

Cylindrical internal thread of flame arrester	Rp (BSP) 3/8	Rp (BSP) 1/2	NPTF 3/8	NPTF 1/2
Tapered outer thread of the pipe line	R 3/8	R 1/2	NPTF 3/8	NPTF 1/2
Width across flat	SW 24			
Fastening screw thread (at special design)	M30x1,5			

The flame arrester should be installed without stress preferably.

There should be always a leak test before putting the plant into operation.

The proving pressures of the flame arrester according to the test certificate EN 10204 must not be exceeded.

5. Maintenance

The maintenance is restricted to a periodical visual examination of the flame arrester, especially of the metal foil elements with regard to contamination and appearance and the cleaning of minor contamination of the metal foil elements.

For this purpose the flame arrester shall be dismantled by taking out the inleading and outleading pipes.

Under any circumstances the flame arrester must not be dismantled on one's own or the retaining ring (3) removed or loosened!

The retaining ring shall be checked on outer mechanical damages and correct position.

Furthermore, the firm position of the screw joints pos. (9) to (11) (tightening torque 6 Nm) shall be checked by means of an Allen wrench.

The contamination level of the outer metal foil element is to be estimated through the connecting threads by lightening with a torch.

In the case of minor contamination the metal foil elements shall be blown out against the operating flow with compressed air or hot vapour.

The periods of the maintenance works depend on the operating conditions and the trend to contamination of each media and shall be defined by the operator.

During the cleaning works no mechanical changes shall be carried out on the flame arrester or its equipment.

For the flame arrester no spare parts will be provided.

On principle, the flame arrester has to be replaced by a new one, if

- a fire occurred on the flame arrester element
- the housing (1), the cover (2) or the retaining ring (3) show visible mechanical damages

Created By:	RMG	Date: 01.01.14	BS&B FlameSAF Limited, Limerick, Ireland
Approved By:	D. Hennessy	Date: 01.01.14	



FLAME ARRESTER
931-B 1/2(3/8)-5x0,2/D
INSTRUCTIONS FOR OPERATING AND MAINTENANCE

REV 1.0

Page 4/4

- the metal foil elements are visibly strongly contaminated
- corrosion damages at the metal foil element have been detected

All works in connection with checking and cleaning of the flame arrester shall be executed only by trained and authorized skilled personnel.

The external leak-proofness of all pressure loaded thread joints shall be checked.

Assembly Drawing

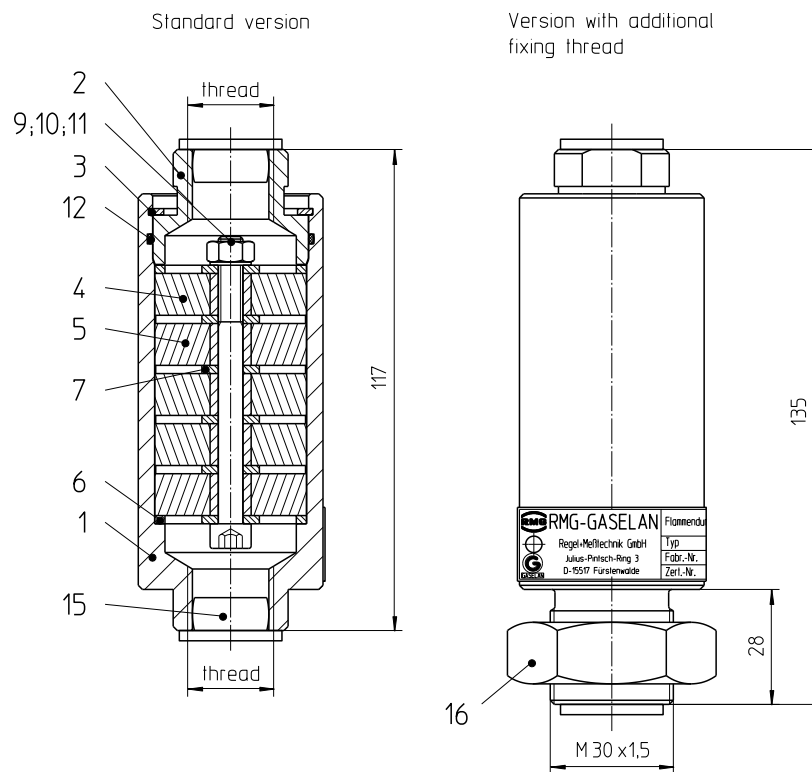

Hazard sign

Warning installation and application limits in accordance with ISO 16852			
DET4	$L_w/D = \dots$	BC : C	$I_{BT} = \dots \text{ min}$
	Ex. G IIC	$T_b = 60^\circ\text{C}$	$P_0 = 0.12 \text{ MPa}$

Created By:	RMG	Date: 01.01.14	BS&B FlameSAF Limited, Limerick, Ireland
Approved By:	D. Hennessy	Date: 01.01.14	